

CB and CSB CALIPER BRAKE

CB PNEUMATIC / HYDRAULIC CALIPER BRAKE

CSB SPRING APPLIED / AIR RELEASE & SPRING APPLIED / HYDRAULIC RELEASE CALIPER BRAKE

MODEL	CB100	CB200	CSB100	CSB200
A	2.5 (63.5)	3.125 (79.4)	3.125 (79.4)	3.375 (85.7)
B	2.625 (66.7)	3.750 (95)	2.65 (67.5)	3.75 (95)
C	2.25 (57.1)	3.125 (79)	2.25 (57.1)	3.13 (79)
D	1.625 (41.3)	2.250 (57)	1.625 (41.3)	2.250 (57)
E	.5 (12.7)	.625 (16)	.5 (12.7)	.625 (16)
F	.438 (11)	.438 (11)	.438 (11)	.438 (11)
MOUNTING BOLTS	.375-16, NC	.5-13, NC	.375-16, NC	.5-13, NC
STATIC TANGENTIAL FORCE @ 80 PSI	125 Lbs (556 N)	250 (1100 N)	75 Lbs (330 N)	150 Lbs (660 N)
LINING AREA	3.3 sq in (21.3 cm ²)	8 sq in (52 cm ²)	3.3 sq in (21.3 cm ²)	8 sq in (52 cm ²)
WEARABLE LINING VOLUME	.33 cu in (5.4 cm ³)	1.0 cu in (16 cm ³)	.30 cu in (4.9 cm ³)	.85 cu in (13.6 cm ³)

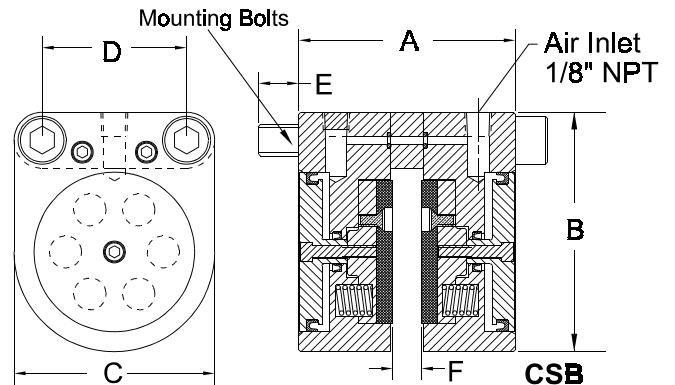
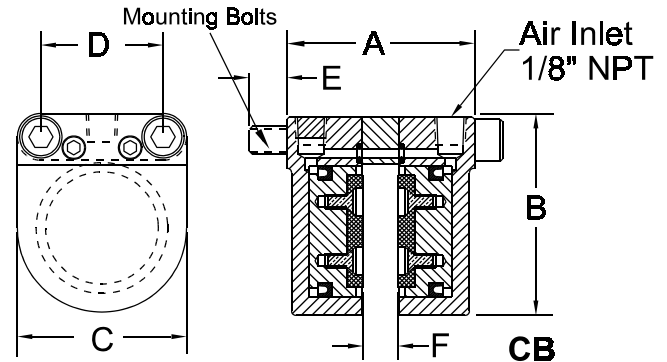

USED ON:

- Packing Machinery
- General Industrial Machinery
- Materials Handling Machinery
- Conveyors
- Textile Machinery
- Paper Industry Machinery
- Printing Machinery
- Food Processing Machinery
- Special Industrial Machinery

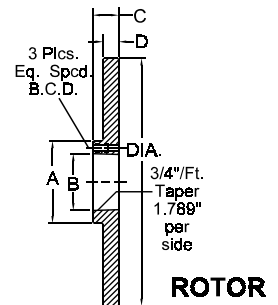

ROTOR

STATIC TORQUE RATINGS AT FULL LINING CSB RELEASE PRESSURE 70PSI AIR PRESSURE OR HYDRAULIC PRESSURE

PART NUMBER	DIA.	A	B	C	D	B.C.D.	QD BUSHING BORE	CB100	CB200	CB100	CB200	CSB100	CSB200
								Static Torque Ratings @ 80PSI Air Pressure		Static Torque Ratings @ 160PSI Hydraulic Pressure		Release Pressure @ 70PSI	
6161	6" (152mm)	2.000	1.375	.625	.375	1.656	"JA" 1 1/4" MAX.	270 IN-LB (2390 Nm)	440 IN-LB (3890 Nm)	540 IN-LB (4780 Nm)	880 IN-LB (7780 Nm)	160 IN-LB (1400 Nm)	265 IN-LB (2330 Nm)
6162	9" (229mm)	2.688	1.871	.875	.375	2.250	"SH" 1 11/16" MAX.	460 IN-LB (4071 Nm)	810 IN-LB (7170 Nm)	920 IN-LB (8142 Nm)	1620 IN-LB (14340 Nm)	275 IN-LB (2420 Nm)	485 IN-LB (4270 Nm)
6163	12" (305mm)	3.875	2.813	1.250	.375	3.313	"SK" 2 3/8" MAX.	650 IN-LB (5753 Nm)	1190 IN-LB (10530 Nm)	1300 IN-LB (11506 Nm)	2380 IN-LB (21060 Nm)	390 IN-LB (3432 Nm)	715 IN-LB (6292 Nm)

*Supplied By Customer

THE CARLSON COMPANY INC. • 6045 N. Broadway • Wichita, Kansas 67219 USA

Phone: 316 744 0481 • Fax: 316 744 2144 • E-mail: info@carlsoncompany.com

www.carlsoncompany.com