

# Heavy Duty Industrial Air Brakes

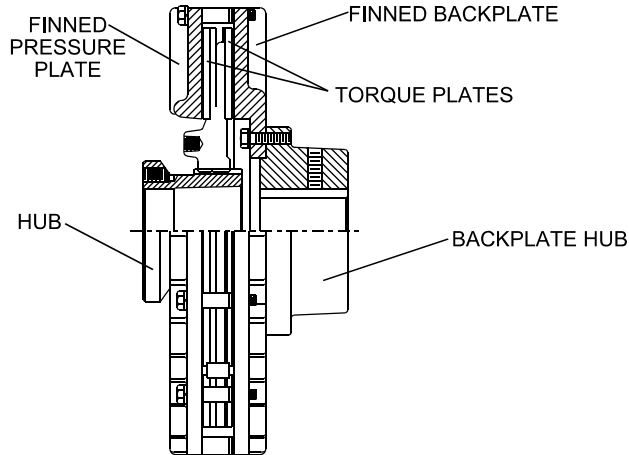

## USED ON:

- Roofing Machinery
- Printing Machinery
- Paper Converting
- Metal Working

**GREATER TORQUE CAPACITY** - The design uses two friction plates and two friction linings. The two friction plates, along with controlled air pressure (up to a recommended maximum of 120 psi) provide high torque capacity in each size clutch. This extra torque can result in the economy of a smaller size clutch in many applications.

**COOLER RUNNING** - Finned pressure plates and backplanes promote better heat dissipation, cooler running, and longer life.

**HIGH TEMPERATURE DIAPHRAGM** - The use of high temperature silicone rubber and Nomex materials in the Power Flo diaphragm give an operating temperature range up to 400 degrees Fahrenheit.

**MORE COMPACT** - The smaller diameter and thinner cross section, features resulting from the diaphragm being positioned between the two friction plates and linings, provide a torque capacity that is greater than other designs of the same size. The compact size and low inertia design allow higher RPM limits.

**POSITIVE DISENGAGEMENT** - The centering mechanism centers the torque assembly between the pressure plate and backplate to eliminate clutch drag. When properly installed, friction can not be transferred between surfaces, so torque is eliminated when the clutch is not engaged.

**EASY ADJUSTMENT** - The contoured diaphragm, expanded with air pressure, automatically compensates for normal lining wear. Adjusting spacers are easily removed for readjusting the pressure plate and backplate within the diaphragm limits.

The Power Flo industrial air brake utilizes the same basic torque assembly as the Power Flo clutch and incorporates a brake flanged hub to hold the torque plates stationary to provide the braking action. The brake flanged hub must be supported by, and fastened to, a stationary bracket for alignment and the bracket must have the capacity to serve as a torque arm. Outside diameter of the hub is held to plus .000, minus .002, permitting easy alignment for pilot mounting to the supporting bracket.

Clutch Size	Torque Rating @80PSI	Max Bore	Max RPM
8.5	4300 In/lbs	3.000"	3000
10	10,200 In/lbs	3.000"	2800
12	17,300 In/lbs	4.000"	2500
14	33,500 In/lbs	4.500"	2400
16	48,200 In/lbs	5.000"	2200
18	77,700 In/lbs	5.500"	2000
20	97,500 In/lbs	6.000"	1800
22	143,100 In/lbs	6.500"	1500
25	210,200 In/lbs	8.000"	1200
28	323,400 In/lbs	8.500"	1000
32	441,400 In/lbs	10.00"	800
36	699,600 In/lbs	11.00"	600