

PE AIR APPLIED-SPRING RELEASE CLUTCH

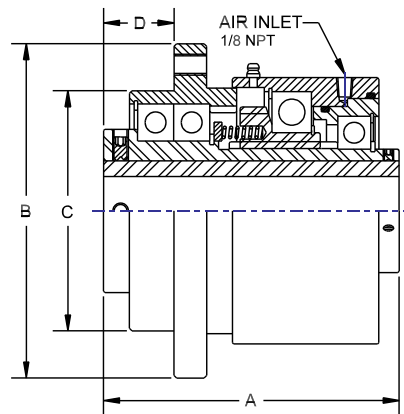

PE

MODEL	BORE +.002 -.001	KEYWAY	A	B	C +.000 -.001	D	M ₁		M ₂		TORQUE IN/LB (Nm)	MAX. RPM	NO. OF TEETH
							TAP	BCD	TAP	BCD			
PE2AS	-1 .750 (19.050)	3/16X1/16 (4.75X1.59)	4.56 (115.82)	4.13 (104.90)	2.875 (73.025)	.938 (23.83)	.25-20	3.437 (87.300)	.313-18	3.562 (90.475)	2,000 (226)	3,600	46
	-2 .875 (22.225)												
PE4AS	-1 1.188 (30.175)	1/4X3/32 (6.35X2.38)	5.19 (131.83)	4.88 (123.95)	3.500 (88.900)	.969 (24.61)	.25-20	4.250 (107.950)	.313-18	4.250 (107.950)	4,000 (452)	3,000	60
	-2 1.250 (31.750)												
PE10AS	-1 1.688 (42.875)	3/8X3/32 (9.53X2.38)	6.06 (153.92)	6.13 (155.70)	4.500 (114.300)	1.16 (29.46)	.313-18	5.250 (133.350)	.50-13	5.375 (136.525)	10,000 (1130)	2,000	48
	-2 1.750 (44.450)												
PE25AS	2.188 (55.575)	1/2X1/8 (12.70X3.18)	7.06 (179.32)	8.00 (203.20)	5.750 (146.050)	1.69 (42.93)	.50-13	7.000 (177.800)	-	-	25,000 (2825)	1,800	58
PE50AS	2.938 (74.625)	3/4X3/16 (19.05X4.75)	8.18 (207.77)	9.50 (241.30)	7.370 (187.198)	2.63 (66.80)	-	-	.50-13	8.500 (215.900)	50,000 (5650)	1,800	78

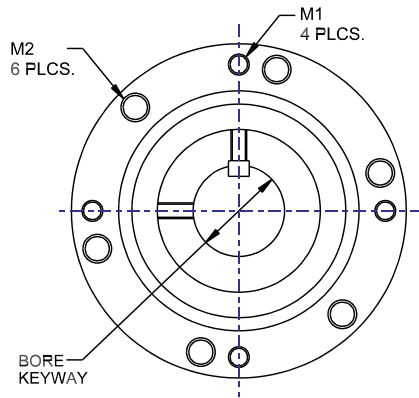
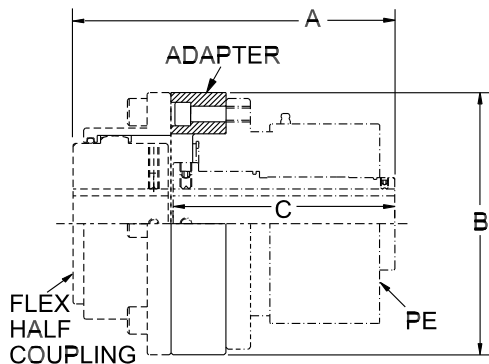

PE WITH COUPLING ADAPTER

MODEL	ADAPTER PART NO.	A	B	C	TORQUE IN/LB (Nm)	MAX. RPM	NO. OF TEETH	FLEX-HALF COUPLING REQUIRED*
PE10 AS/SA	4635A	8.125 (206.375)	6.250 (158.750)	6.063 (154.000)	10,000 (1,130)	2,000	48	1015G
PE25 AS	4636A	10.250 (260.350)	8.375 (212.725)	7.063 (179.400)	25,000 (2,825)	1,800	58	1025G
PE50 AS	4637A	12.563 (319.100)	9.438 (239.725)	8.812 (223.825)	50,000 (15,600)	1,800	78	1030G

* Flex-Half Coupling supplied by customer (Falk or Equivalent)

NOTE: UNIT WILL NOT DISENGAGE UNDER LOAD

PE Clutches use O-rings as dynamic seals, therefore adequate lubrication must be provided in the actuating air circuit to ensure these O-rings do not run dry.

THE CARLSON CO. INC. USA

Fax: (316) 744-2144 • Phone: (316) 744-0481
www.carlsoncompany.com

2008

F - 2

() - contains metric dimensions