

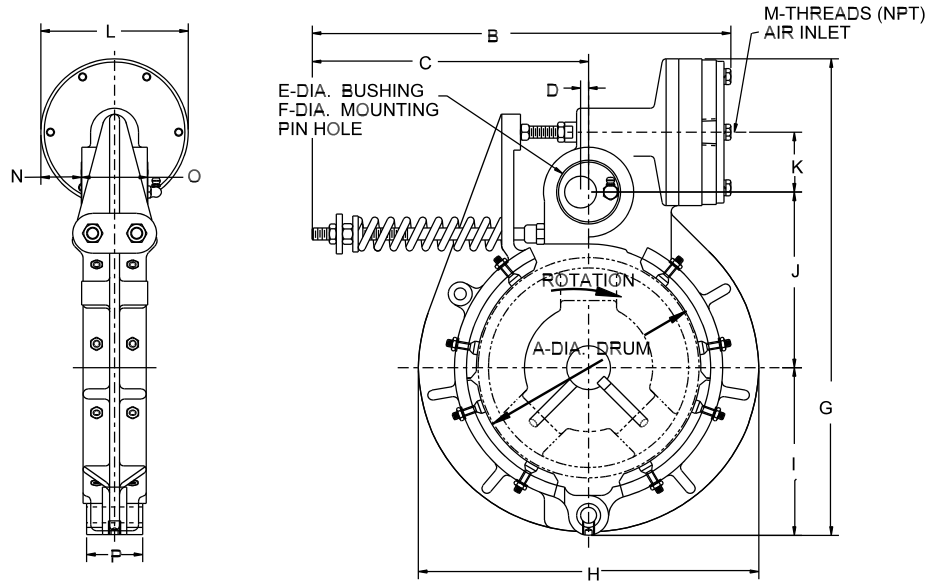

MODEL SB SHOE BRAKE



BRAKE MODEL	A	B	C	D	E	F ±.002	G	H	I	J	K	L	M	N	O	P
7SB200	7	12-7/8 (314)	8-1/8 (206)	1/4 (6)	2 (50)	1.002 (25.451)	15-1/8 (384)	10-7/8 (276)	5-3/8 (136)	5-1/2 (139)	1-7/8 (47)	4-1/2 (114)	3/8 (9)	1-3/8 (34)	1-3/4 (44)	2 (50)
10SB275	10	13-1/4 (336)	8-3/8 (212)	3/8 (9)	2-1/2 (63)	1.252 (31.801)	19-1/2 (495)	15 (381)	7 (177)	7-7/16 (188)	2-7/16 (61)	5-1/4 (133)	3/8 (9)	1-5/16 (33)	2-5/8 (66)	2-3/4 (69)
14SB350	14	15-1/2 (393)	9-5/8 (244)	5/8 (15)	3-1/4 (82)	1.502 (38.151)	25-1/2 (647)	19-3/4 (501)	9-3/4 (247)	10-1/8 (257)	2-5/8 (66)	5-1/4 (133)	3/8 (9)	1 (25)	3-1/4 (82)	3-1/2 (88)

BRAKE MODEL	WEIGHT LBS (Kg) APPROX.	TORQUE RATING IN - LB (Nm)	RELEASE PRESSURE PSI (Bar)
7SB200	24 (11)	4940 (558)	50 (3.6)
10SB275	39 (18)	9530 (1077)	50 (3.6)
14SB350	70 (32)	15300 (1729)	50 (3.6)

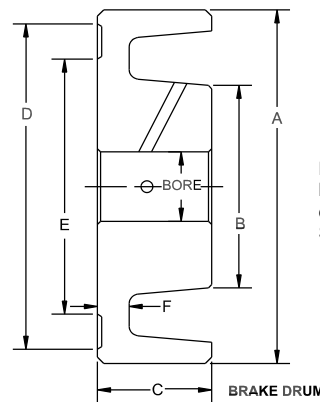

Model SB shoe brake drums may be bored to fit existing shaft diameters. Standard tolerance on the bore is

SB BRAKE DRUM

SHOE BRAKE MODEL	DRUM PART NO.	A	B	C	D	E	F	BORE MIN.	BORE MAX. STANDARD KEYWAY	BORE MAX. SHALLOW KEYWAY	Weight LBS. (Kg) APPROX.	LINING KIT
7SB200	3089-1	7.000	4 (101)	2.250 (57)	-	-	5/8 (15.9)	1.50 (38.1)	2.750 (69.85)	3.000 (76.20)	15 (7)	2405K
10SB275	3089-2	10.000	4-3/4 (120)	3.000 (76)	-	-	3/4 (19.1)	2.00 (50.8)	3.250 (82.55)	3.500 (88.90)	37 (17)	2406K
14SB350	3089-3	14.000	6-1/2 (165)	3.750 (95)	12-3/4 (323)	8-3/4 (222)	1-1/8 (28.6)	2.50 (63.5)	4.375 (111.13)	5.000 (127.00)	92 (41)	2407K

THE CARLSON CO. INC. USA

Fax: (316) 744-2144 • Phone: (316) 744-0481
www.carlsoncompany.com

2008

E-9

() - contains metric dimensions
Dimensions shown are for general information only.
Certified prints will be furnished upon request for design and installation purposes.