

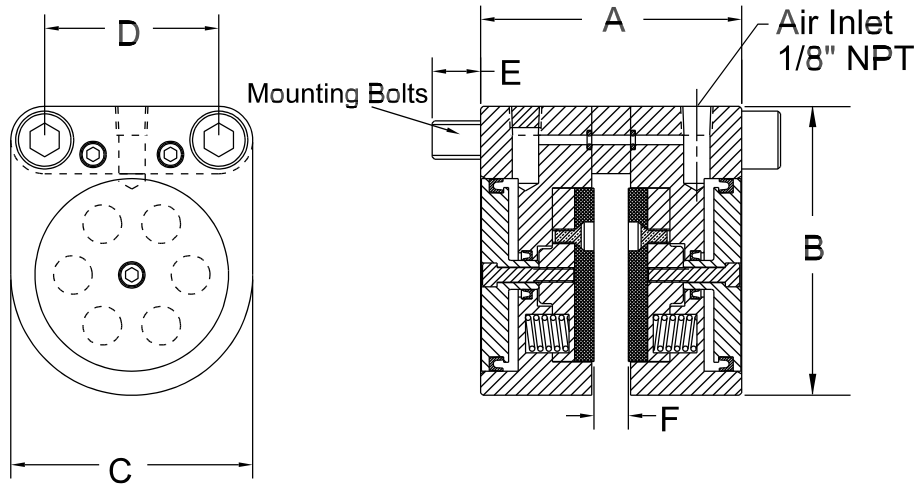

## CSB CALIPER BRAKE SPRING APPLIED / AIR RELEASE



MODEL	A	B	C	D	E	F	MOUNTING BOLTS	STATIC TANGENTIAL FORCE	LINING AREA	WEARABLE LINING VOLUME
CSB100	3.125 (79.4)	2.65 (67.5)	2.25 (57.1)	1.625 (41.3)	.5 (12.7)	.438 (11)	.375-16, NC	75 Lbs (330 N)	3.3 sq in (21.3 cm <sup>2</sup> )	.30 cu in (4.9 cm <sup>3</sup> )
CSB200	3.375 (85.7)	3.75 (95)	3.13 (79)	2.250 (57)	.625 (16)	.438 (11)	.5-13, NC	150 Lbs (660 N)	8 sq in (52 cm <sup>2</sup> )	.85cu in (13.6 cm <sup>3</sup> )

### SPECIFICATIONS STATIC TORQUE RATINGS AT FULL LINING RELEASE PRESSURE 70PSI

PART NUMBER	DIA.	A	B	C	D	B.C.D.	QD BUSHING BORE	CSB100	CSB200
								Release Pressure @ 70PSI	
6161	6" (152mm)	2.000	1.375	.625	.375	1.656	"JA"*** 1 1/4" MAX.	160 IN-LB (18 NM)	265 IN-LB (30 NM)
6162	9" (229mm)	2.688	1.871	.875	.375	2.250	"SH"*** 1 11/16" MAX.	275 IN-LB (31 NM)	485 IN-LB (55 NM)
6163	12" (305mm)	3.875	2.813	1.250	.375	3.313	"SK"*** 2 3/8" MAX.	390 IN-LB (44 NM)	715 IN-LB (81 NM)

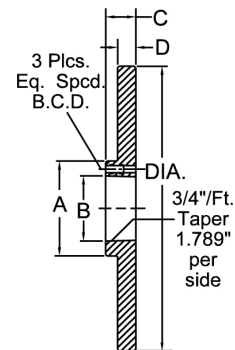

\* Supplied By Customer