

## SPRING APPLIED / AIR RELEASED ENCLOSED BRAKE

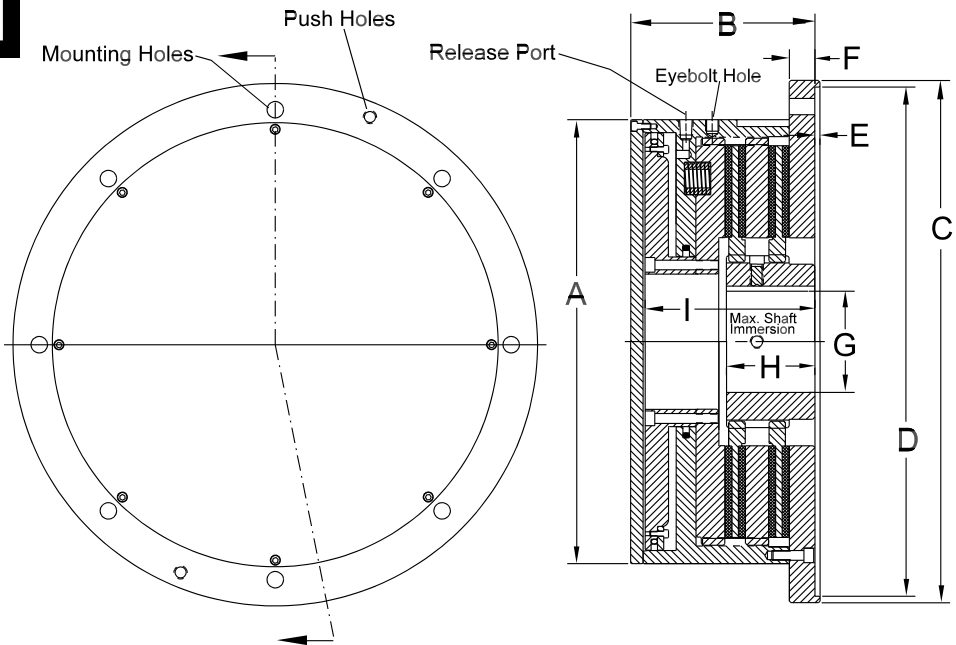

MODEL	A	B	C	D	E	F	G MAX. BORE	H	I	MOUNTING HOLES	RELEASE PORT
SAB212	14 (355.6)	6.781 (172.237)	16.5 (419.1)	16.003 (406.4)	.188 (4.775)	.750 (18.542)	2.875 (60.350)	3.125 (79.375)	6.3 (160)	.65 DIA. 8 PLCS. 14.000 BCD	1/4-18, NPT
SAB215	17 (431.8)	7 (177.8)	20 (508)	19.503 (495.427)	.188 (4.775)	1 (25.4)	3.875 (98.476)	3.375 (85.735)	6.5 (165.1)	.65 DIA. 8 PLCS. 18.000 BCD	1/4-18,NPT

### SPECIFICATIONS

MODEL	TORQUE (IN-LB)		RELEASE PRESSURE	LINING AREA (IN <sup>2</sup> )	HEAT CAPACITY (FT-LB)	MAX RPM	WEIGHT LBS.
	NEW	WORN					
SAB212	38000	28000	75 PSI	320	260,000	1800	225
SAB215	73000	53000	75 PSI	505	415,000	1800	375