

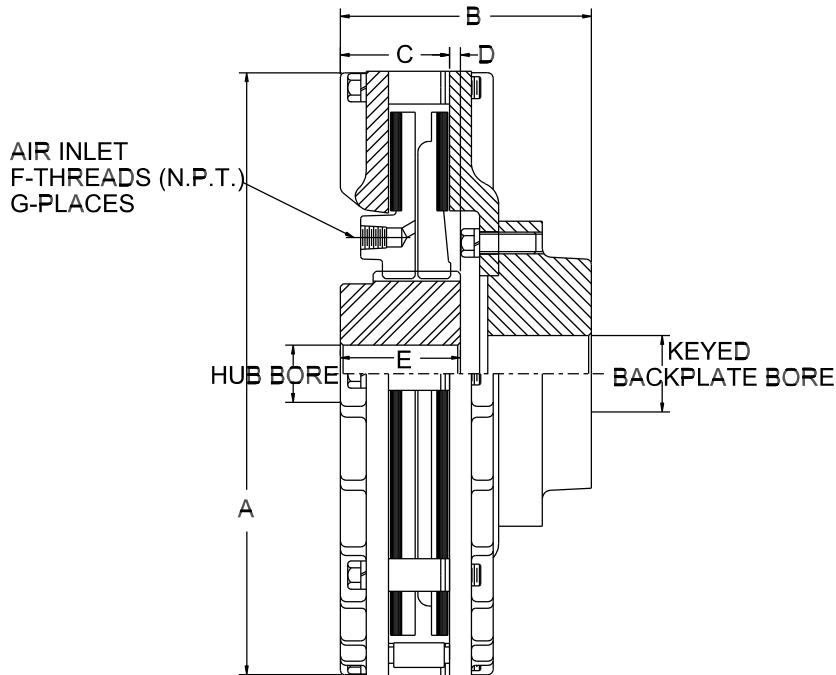

# MODEL CK CLUTCH SIZE 16-18-20-22



MODEL	A	B	C	D	E	F	G	HUB BORE			KEYED BACKPLATE BORE			PRESSURE PLATE* WK <sup>2</sup> Lb-Ft <sup>2</sup> (Kg-Cm <sup>2</sup> )	TORQUE PLATE WK <sup>2</sup> Lb-Ft <sup>2</sup> (Kg-Cm <sup>2</sup> )	Weight Lbs. (Kg) Approx.
								Min. Bore	Max. Bore Standard Keyway	Max. Bore Shallow Keyway	Min. Bore	Max. Bore Standard Keyway	Max. Bore Shallow Keyway			
16	17.87 (453.9)	7.00 (177.8)	2.75 (69.9)	.37 (9.4)	3.00 (76.2)	3/8	2	1.68 (42.7)	3.500 (88.9)	3.875 (98.4)	2.50 (63.5)	4.500 (114.3)	4.500 (114.3)	25.16 (10617.5)	9.57 (4038.5)	173 (78.5)
18	19.87 (504.7)	7.87 (199.9)	2.87 (72.9)	.37 (9.4)	3.00 (76.2)	3/8	2	1.68 (42.7)	3.500 (88.9)	3.875 (98.4)	2.50 (63.5)	5.00 (127.0)	5.500 (139.7)	42.95 (18124.9)	14.64 (6178.1)	222 (100.8)
20	22.25 (565.2)	8.69 (220.7)	3.19 (81.0)	.50 (12.7)	4.00 (101.6)	3/8	3	2.75 (69.9)	4.625 (117.5)	5.125 (130.2)	3.50 (88.9)	5.250 (133.4)	6.000 (152.4)	76.44 (32257.7)	26.30 (11098.6)	300 (136.2)
22	24.25 (616.0)	9.25 (235.0)	3.25 (82.6)	.50 (12.7)	4.00 (101.6)	3/8	3	2.75 (69.9)	4.625 (117.5)	5.125 (130.2)	4.00 (101.6)	5.500 (139.7)	6.500 (165.1)	108.90 (45955.8)	40.10 (16922.2)	383 (173.9)

\*Includes Pressure plate, Cap screws and Spacer.

## REPAIR KITS

MODEL	TORQUE (IN-LBS)** @ 60 PSI LOCO LINING (Nm @ 4.3Bar)	TORQUE (IN-LBS)** @ 80 PSI STANDARD LINING (Nm @ 5.7Bar)	MAXIMUM RPM
16	11792 (1332)	48196 (5446)	2200
18	19090 (2157)	77684 (8778)	2000
20	23879 (2698)	97543 (11022)	1800
22	35159 (3973)	143120 (16172)	1500

HARDWARE KITS CONTAINS- CAPSCREWS, LOCKWASHERS, SPACERS, ADJUSTMENT SPACERS		CENTERING MECHANISM KITS CONTAINS - LOCKNUTS, STUDS, SPRINGS, SCREWS, LOCKWASHERS, CENTERING MECHANISM BRACKETS	
SIZE	PART NUMBER	SIZE	PART NUMBER
16	4014-5	16	4013-6
18	4014-6	18	4013-6
20	4014-7	20	4013-8
22	4014-8	22	4013-8

\*\* The initial torque on new units may be up to 40% less than torque values shown until the friction lining is worn in.

**THE CARLSON CO. INC. USA**

Fax: (316) 744-2144 • Phone: (316) 744-0481  
www.carlsoncompany.com

2008

D - 9

( ) - contains metric dimensions  
Dimensions shown are for general information only.  
Certified prints will be furnished upon request for design and installation purposes.