

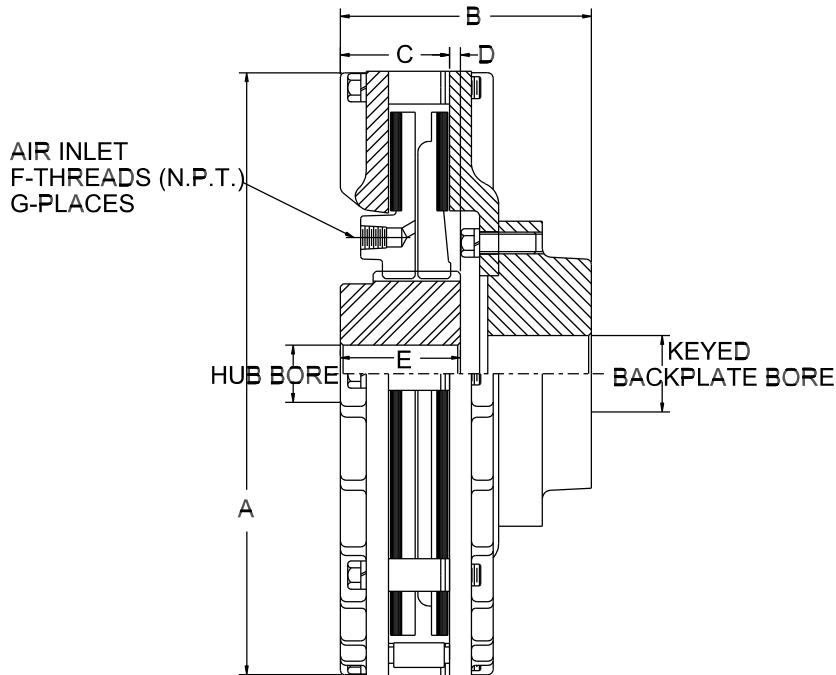

# MODEL CK CLUTCH SIZE 8.5-10-12-14



MODEL	A	B	C	D	E	F	G	HUB BORE			KEYED BACKPLATE BORE			PRESSURE PLATE* WK <sup>2</sup> Lb-Ft <sup>2</sup> (Kg-Cm <sup>2</sup> )	TORQUE PLATE WK <sup>2</sup> Lb-Ft <sup>2</sup> (Kg-Cm <sup>2</sup> )	Weight Lbs. (Kg) Approx.
								Min. Bore	Max. Bore Standard Keyway	Max. Bore Shallow Keyway	Min. Bore	Max. Bore Standard Keyway	Max. Bore Shallow Keyway			
8.5	10.00 (254.0)	4.56 (115.8)	2.31 (58.7)	.25 (6.4)	2.50 (63.5)	1/4	2	1.18 (30.0)	2.000 (50.8)	2.125 (54.0)	1.25 (31.8)	2.625 (66.7)	3.000 (76.2)	2.23 (941.1)	0.70 (295.4)	40 (18.2)
10	11.50 (292.1)	5.12 (130.0)	2.37 (60.2)	.25 (6.4)	2.50 (63.5)	1/4	2	1.18 (30.00)	2.000 (50.8)	2.125 (54.0)	1.50 (38.1)	2.625 (66.7)	3.000 (76.2)	3.69 (1557.2)	1.35 (569.7)	54 (24.5)
12	13.87 (352.3)	5.77 (146.6)	2.52 (64.0)	.25 (6.4)	2.75 (69.9)	1/4	2	1.68 (42.7)	2.875 (73.0)	3.250 (83.0)	2.00 (50.8)	3.625 (92.1)	4.000 (101.6)	9.01 (3802.2)	2.79 (1177.4)	91 (41.3)
14	15.87 (403.1)	6.27 (159.3)	2.52 (64.0)	.25 (6.4)	2.75 (69.9)	1/4	2	1.68 (42.7)	2.875 (73.0)	3.250 (83.0)	2.00 (50.8)	4.125 (104.8)	4.500 (114.3)	13.43 (5667.5)	5.90 (2489.8)	118 (53.6)

\*Includes Pressure plate, Cap screws and Spacer.

## REPAIR KITS

MODEL	TORQUE (IN-LBS)** @ 60 PSI LOCO LINING (Nm @ 4.3Bar)	TORQUE (IN-LBS)** @ 80 PSI STANDARD LINING (Nm @ 5.7Bar)	MAXIMUM RPM
8.5	1045 (118)	4290 (485)	3000
10	2501 (283)	10169 (1149)	2800
12	4232 (478)	17322 (1957)	2500
14	8251 (932)	33548 (3791)	2400

HARDWARE KITS CONTAINS- CAPSCREWS, LOCKWASHERS, SPACERS, ADJUSTMENT SPACERS		CENTERING MECHANISM KITS CONTAINS - LOCKNUTS, STUDS, SPRINGS, SCREWS, LOCKWASHERS, CENTERING MECHANISM BRACKETS	
SIZE	PART NUMBER	SIZE	PART NUMBER
8.5	4014-1	8.5	4013-2
10	4014-2	10	4013-2
12	4014-3	12	4013-4
14	4014-4	14	4013-4

\*\* The initial torque on new units may be up to 40% less than torque values shown Until the friction lining is worn in.

**THE CARLSON CO. INC. USA**  
Fax: (316) 744-2144 • Phone: (316) 744-0481  
www.carlsoncompany.com

2008

D - 8

( ) - contains metric dimensions  
Dimensions shown are for general information only.  
Certified prints will be furnished upon request for design and installation purposes.