

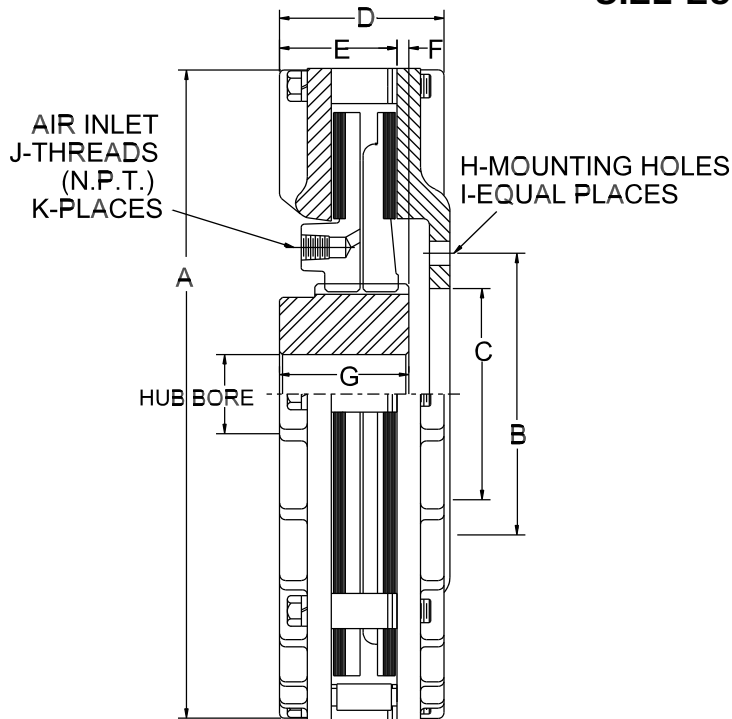

MODEL CR CLUTCH SIZE 25 - 28 - 32 - 36



MODEL	A	B	C	D	E	F	G	H	I	J	K	HUB BORE			PRESSURE PLATE* WK ² Lb-Ft ² (Kg-Cm ²)	TORQUE PLATE WK ² Lb-Ft ² (Kg-Cm ²)	Weight Lbs. Approx. (Kg)
												Min. Bore	Max. Bore Standard Keyway	Max. Bore Shallow Keyway			
25	27.25 (692.2)	12.000 (304.8)	10.000 (254.0)	5.87 (149.1)	4.00 (101.6)	.62 (15.7)	5.00 (127.0)	49/64	10	1/2	3	2.75 (69.9)	5.625 (142.9)	6.250 (158.8)	199.90 (84357.8)	76.05 (32093.1)	440 (199.8)
28	30.25 (768.4)	13.000 (330.2)	11.000 (279.4)	6.50 (165.1)	4.31 (109.5)	.62 (15.7)	5.00 (127.0)	49/64	12	1/2	3	2.75 (69.9)	5.625 (142.9)	6.250 (158.8)	357.60 (150907.2)	122.20 (51568.4)	580 (263.3)
32	34.25 (870.0)	15.000 (381.0)	12.500 (317.5)	7.31 (185.7)	4.81 (122.2)	1.25 (31.8)	6.00 (152.4)	1-1/64	12	1/2	3	4.00 (101.6)	8.000 (203.2)	8.500 (215.9)	667.00 (281474.0)	233.80 (98663.6)	925 (420.0)
36	38.25 (971.6)	17.000 (431.8)	14.000 (355.6)	8.06 (204.7)	5.06 (128.5)	1.25 (31.8)	6.00 (152.4)	1-1/64	12	1/2	3	4.00 (101.6)	8.000 (203.2)	8.500 (215.9)	1208.40 (509944.8)	363.28 (153304.2)	1260 (572.0)

*Includes Pressure plate, Back plate, Cap screws and Spacers.

REPAIR KITS

MODEL	TORQUE (IN-LBS)** @ 60 PSI LOCO LINING (Nm @ 4.3Bar)	TORQUE (IN-LBS)** @ 80 PSI STANDARD LINING (Nm @ 5.7Bar)	MAXIMUM RPM
25	51677 (5840)	210200 (23753)	1200
28	79730 (9009)	323454 (36550)	1000
32	108419 (12251)	441370 (49875)	800
36	172387 (19480)	699637 (79059)	600

HARDWARE KITS CONTAINS- CAPSCREWS, LOCKWASHERS, SPACERS, ADJUSTMENT SPACERS		CENTERING MECHANISM KITS CONTAINS - LOCKNUTS, STUDS, SPRINGS, SCREWS, LOCKWASHERS, CENTERING MECHANISM BRACKETS	
SIZE	PART NUMBER	SIZE	PART NUMBER
25	4014-9	25	4013-10
28	4014-10	28	4013-10
32	4014-11	32	4013-12
36	4014-12	36	4013-12

** The initial torque on new units may be up to 40% less than torque values shown until the friction lining is worn in.

THE CARLSON CO. INC. USA

Fax: (316) 744-2144 • Phone: (316) 744-0481
www.carlsoncompany.com

2008

D-7

() - contains metric dimensions
Dimensions shown are for general information only.
Certified prints will be furnished upon request for design and installation purposes.