

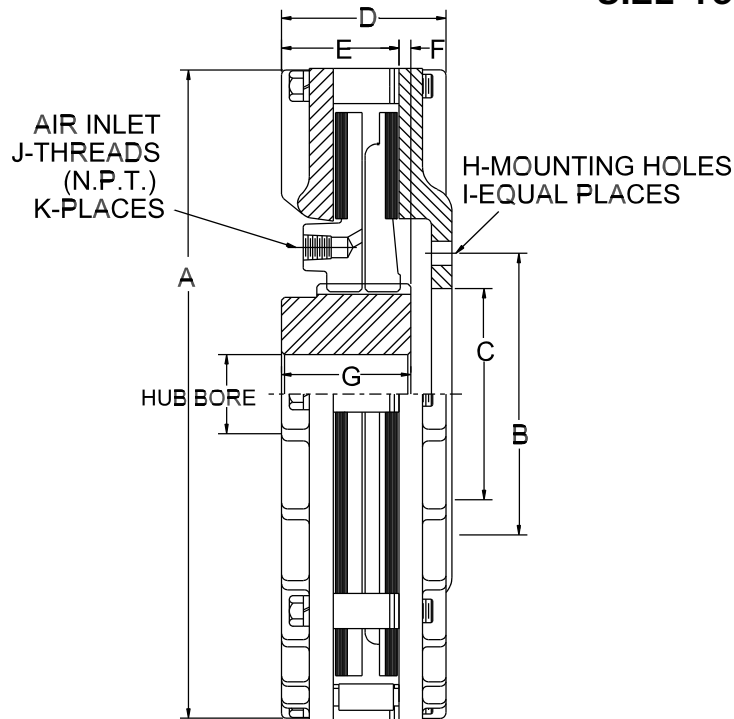

MODEL CR CLUTCH SIZE 16 - 18 - 20 - 22



MODEL	A	B	C	D	E	F	G	H	I	J	K	HUB BORE			PRESSURE PLATE* WK ² Lb-Ft ² (Kg-Cm ²)	TORQUE PLATE WK ² Lb-Ft ² (Kg-Cm ²)	Weight Lbs. Approx. (Kg)
												Min. Bore	Max. Bore Standard Keyway	Max. Bore Shallow Keyway			
16	17.87 (453.9)	7.500 (190.5)	6.000 (152.4)	4.00 (101.6)	2.75 (69.9)	.37 (9.4)	2.50 (63.5)	33/64	8	3/8	2	1.68 (42.7)	3.500 (88.9)	3.875 (98.43)	23.16 (9773.5)	9.57 (4038.5)	137 (62.2)
18	19.87 (504.7)	8.250 (209.6)	6.500 (165.1)	4.25 (108.0)	2.87 (72.9)	.37 (9.4)	2.50 (63.5)	33/64	8	3/8	2	1.68 (42.7)	3.500 (88.9)	3.875 (98.43)	40.00 (16880.0)	14.64 (6178.1)	172 (78.1)
20	22.25 (565.2)	9.000 (228.6)	7.500 (190.5)	4.69 (119.1)	3.19 (81.0)	.50 (12.7)	2.75 (69.9)	41/64	8	3/8	3	2.75 (69.9)	4.625 (117.5)	5.125 (130.2)	71.84 (30316.5)	26.30 (11098.6)	240 (109.0)
22	24.25 (616.0)	9.750 (247.7)	8.000 (203.2)	4.81 (122.2)	3.25 (82.6)	.50 (12.7)	2.75 (69.9)	41/64	8	3/8	3	2.75 (69.9)	4.625 (117.5)	5.125 (130.2)	102.60 (43297.2)	40.10 (16922.2)	310 (140.7)

*Includes Pressure plate, Back plate, Cap screws and Spacers.

REPAIR KITS

MODEL	TORQUE (IN-LBS)** @ 60 PSI LOCO LINING (Nm @ 4.3Bar)	TORQUE (IN-LBS)** @ 80 PSI STANDARD LINING (Nm @ 5.7Bar)	MAXIMUM RPM
16	11792 (1332)	48196 (5446)	2200
18	19090 (2157)	77684 (8778)	2000
20	23879 (2698)	97543 (11022)	1800
22	35159 (3973)	143120 (16173)	1500

HARDWARE KITS CONTAINS- CAPSCREWS, LOCKWASHERS, SPACERS, ADJUSTMENT SPACERS		CENTERING MECHANISM KITS CONTAINS - LOCKNUTS, STUDS, SPRINGS, SCREWS, LOCKWASHERS, CENTERING MECHANISM BRACKETS	
SIZE	PART NUMBER	SIZE	PART NUMBER
16	4014-5	16	4013-6
18	4014-6	18	4013-6
20	4014-7	20	4013-8
22	4014-8	22	4013-8

** The initial torque on new units may be up to 40% less than torque values shown until the friction lining is worn in.

THE CARLSON CO. INC. USA

Fax: (316) 744-2144 • Phone: (316) 744-0481
www.carlsoncompany.com

2008

D-6

() - contains metric dimensions
Dimensions shown are for general information only.
Certified prints will be furnished upon request for design and installation purposes.