

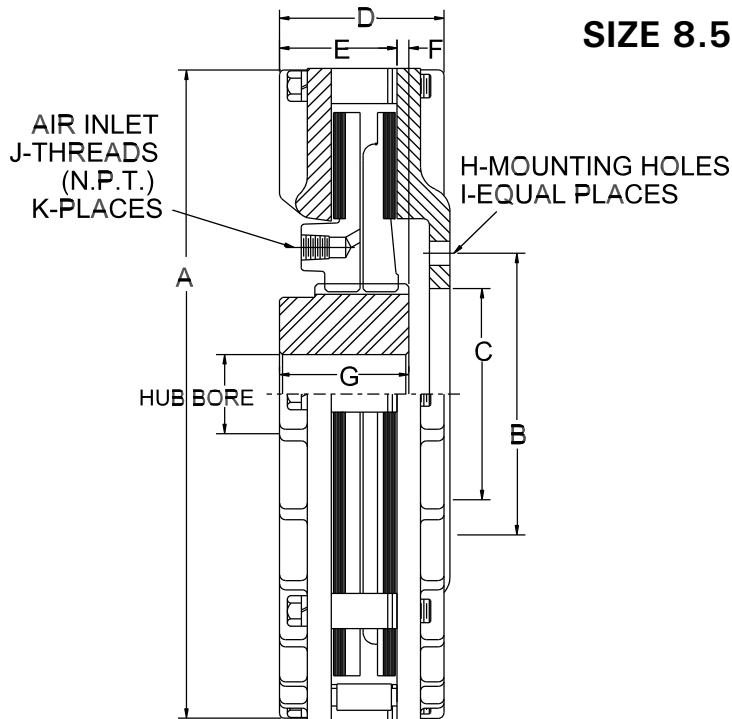

MODEL CR CLUTCH

SIZE 8.5 - 10 - 12 - 14



MODEL	A	B	C	D	E	F	G	H	I	J	K	HUB BORE			PRESSURE PLATE* WK ² Lb-Ft ² (Kg-Cm ²)	TORQUE PLATE WK ² Lb-Ft ² (Kg-Cm ²)	Weight Lbs. Approx. (Kg)
												Min. Bore	Max. Bore Standard Keyway	Max. Bore Shallow Keyway			
8.5	10.00 (259.0)	4.375 (111.1)	3.375 (85.7)	3.25 (82.6)	2.31 (58.7)	.25 (6.4)	2.50 (63.5)	25/64	6	1/4	2	1.18 (30.0)	2.000 (50.8)	2.125 (54.0)	2.10 (886.2)	.70 (295.4)	34 (15.4)
10	11.50 (292.1)	5.000 (127.0)	4.000 (101.6)	3.37 (85.6)	2.37 (60.2)	.25 (6.4)	2.50 (63.5)	25/64	8	1/4	2	1.18 (30.0)	2.000 (50.8)	2.125 (54.0)	3.43 (1447.5)	1.35 (569.7)	44 (20.0)
12	13.87 (352.3)	6.000 (152.4)	4.500 (114.3)	3.65 (92.7)	2.52 (64.0)	.25 (6.4)	2.75 (69.9)	33/64	6	1/4	2	1.68 (42.7)	2.875 (73.0)	3.250 (82.6)	8.47 (3574.3)	2.79 (1177.4)	78 (35.4)
14	15.87 (403.1)	6.500 (165.1)	5.000 (127.0)	3.65 (92.7)	2.52 (64.0)	.25 (6.4)	2.75 (69.9)	33/64	6	1/4	2	1.68 (42.7)	2.875 (73.0)	3.250 (82.6)	12.45 (5253.90)	5.90 (2489.80)	95 (43.1)

*Includes Pressure plate, Back plate, Cap screws and Spacers.

REPAIR KITS

MODEL	TORQUE (IN-LBS)** @ 60 PSI LOCO LINING (Nm @ 4.3Bar)	TORQUE (IN-LBS)** @ 80 PSI STANDARD LINING (Nm @ 5.7Bar)	MAXIMUM RPM
8.5	1045 (118)	4290 (485)	3000
10	2501 (283)	10169 (1149)	2800
12	4232 (478)	17322 (1957)	2500
14	8251 (932)	33548 (3791)	2400

HARDWARE KITS CONTAINS- CAPSCREWS, LOCKWASHERS, SPACERS, ADJUSTMENT SPACERS		CENTERING MECHANISM KITS CONTAINS - LOCKNUTS, STUDS, SPRINGS, SCREWS, LOCKWASHERS, CENTERING MECHANISM BRACKETS	
SIZE	PART NUMBER	SIZE	PART NUMBER
8.5	4014-1	8.5	4013-2
10	4014-2	10	4013-2
12	4014-3	12	4013-4
14	4014-4	14	4013-4

** The initial torque on new units may be up to 40% less than torque values shown until the friction lining is worn in.

THE CARLSON CO. INC. USA

Fax: (316) 744-2144 • Phone: (316) 744-0481
www.carlsoncompany.com

2008

D-5

() - contains metric dimensions
Dimensions shown are for general information only.
Certified prints will be furnished upon request for design and installation purposes.