

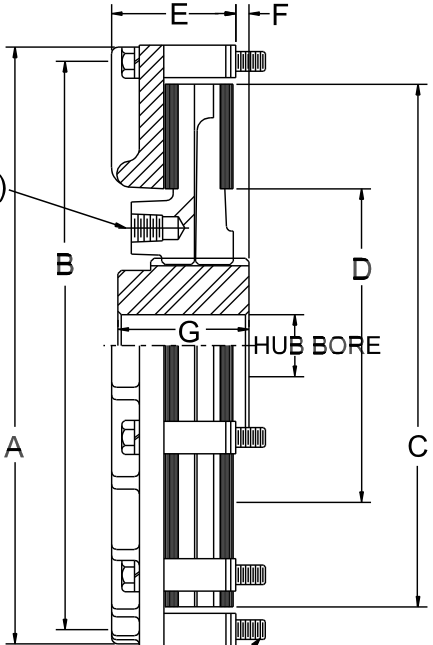

MODEL CW CLUTCH SIZE 25 - 28 - 32 - 36

AIR INLET
K-PLACES
J-THREADS (N.P.T.)



H-CAP SCREWS
I-EQUAL PLACES

MODEL	A	B	C	D	E	F	G	H	I	J	K	HUB BORE			PRESSURE PLATE* WK ² Lb-Ft ² (Kg-Cm ²)	TORQUE PLATE WK ² Lb-Ft ² (Kg-Cm ²)	Weight Lbs. Approx. (Kg)
												Min. Bore	Max. Bore Standard Keyway	Max. Bore Shallow Keyway			
25	27.25 (692.2)	26.250 (666.8)	25.00 (635.0)	14.50 (368.3)	4.00 (101.6)	.62 (15.7)	5.00 (127.0)	5/8-18	16	1/2	3	2.75 (69.9)	5.625 (142.9)	6.250 (158.8)	110.29 (46542.4)	76.05 (32093.1)	320 (145.28)
28	30.25 (768.4)	29.250 (743.0)	28.00 (711.2)	16.00 (406.4)	4.31 (109.5)	.62 (15.7)	5.00 (127.0)	5/8-18	20	1/2	3	2.75 (69.9)	5.625 (142.9)	6.250 (158.8)	182.80 (77141.6)	122.20 (51568.4)	410 (186.10)
32	34.25 (870.0)	33.250 (844.6)	32.00 (812.8)	17.75 (450.9)	4.81 (122.2)	1.25 (31.8)	6.00 (152.4)	5/8-18	24	1/2	3	4.00 (101.6)	8.000 (203.2)	8.500 (215.9)	334.60 (141201.2)	233.80 (98663.6)	670 (304.18)
36	38.25 (971.6)	37.250 (946.2)	36.00 (914.4)	19.75 (501.7)	5.06 (128.5)	1.25 (31.8)	6.00 (152.4)	5/8-18	30	1/2	3	4.00 (101.6)	8.000 (203.2)	8.500 (215.9)	618.80 (261133.6)	363.28 (153304.2)	880 (399.52)

*Includes Pressure plate, Cap screws and Spacers.

REPAIR KITS

MODEL	TORQUE (IN-LBS)** @ 60 PSI LOCO LINING (Nm @ 4.3Bar)	TORQUE (IN-LBS)** @ 80 PSI STANDARD LINING (Nm @ 5.7Bar)	MAXIMUM RPM
25	51677 (5839)	210200 (23752)	1200
28	79730 (9009)	323454 (36550)	1000
32	108419 (12251)	441370 (49874)	800
36	172387 (19479)	699637 (79058)	600

HARDWARE KITS CONTAINS- CAPSCREWS, LOCKWASHERS, SPACERS, ADJUSTMENT SPACERS		CENTERING MECHANISM KITS CONTAINS - LOCKNUTS, STUDS, SPRINGS, SCREWS, LOCKWASHERS, CENTERING MECHANISM BRACKETS	
SIZE	PART NUMBER	SIZE	PART NUMBER
25	4014-9	25	4013-10
28	4014-10	28	4013-10
32	4014-11	32	4013-12
36	4014-12	36	4013-12

** The initial torque on new units may be up to 40% less than torque values shown until the friction lining is worn in.

THE CARLSON CO. INC. USA
Fax: (316) 744-2144 • Phone: (316) 744-0481
www.carlsoncompany.com

2008

D-4

() - contains metric dimensions
Dimensions shown are for general information only.
Certified prints will be furnished upon request for design and installation purposes.