

# MODEL TSC60PM

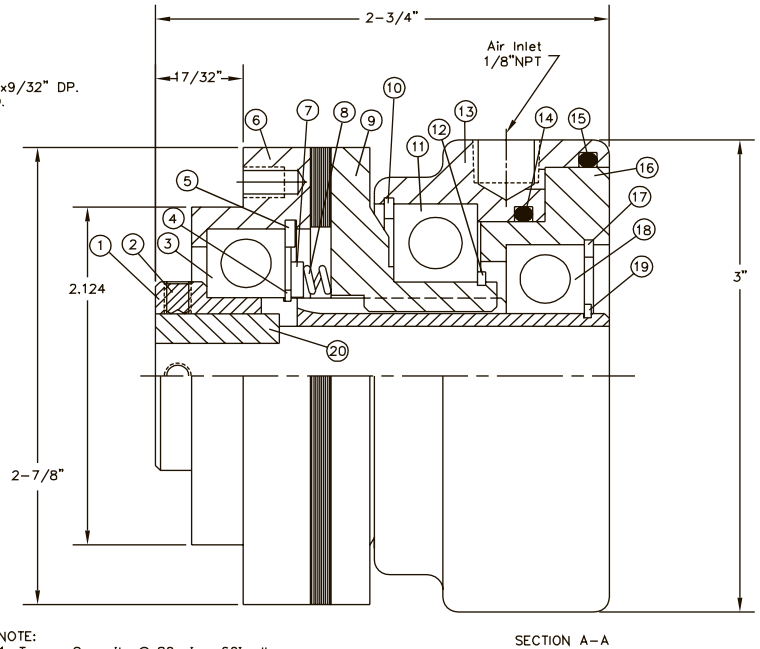
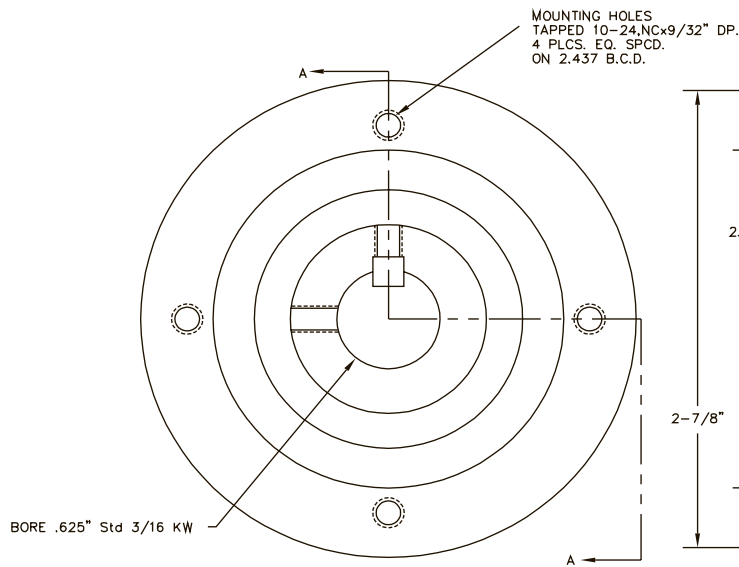

NOTE:  
1. Torque Capacity @ 80psi = 60in-lb

## GENERAL DESCRIPTION

The model TSC150PM is a pneumatic clutch that will couple a sheave or sprocket to a shaft when air pressure between 20psi and 80psi is applied to the Inlet port. This model is made with locating surfaces and a bolt hole pattern for mounting a sheave or sprocket to the output plates of the clutch and a thru-bore for mounting the unit on the shaft. The unit is assembled and ready for mounting as shipped.

## INSTALLATION

Bolt the sheave or sprocket to the backplate of the clutch using (4) 1/4" coarse thread capscrews of the appropriate length. The tapped holes in the backplate are 7/16" deep. Coat the mounting area of the shaft with "Molykote" and install the key provided in the shaft's keyway.

Slide the unit onto the shaft and into position.

Do not use a hammer to position the unit as bearing damage may occur.

Once the unit is in position on the shaft, lock it down by tightening the set-screws.

Install the air line to the 1/8"NPT inlet port. Use a dryer and a lubricator in the air line to prevent internal rust and promote long life. Check the unit several times after putting it into use to be sure it is not running hot. The maximum shell temperature should be 180°F.

## MAINTENANCE

This model clutch has no items requiring maintenance or adjustment. Items which have limited life and may eventually need replacing include: friction discs, o-rings, and bearings. The items are available in a repair kit as shown on the parts list.

ITEM	DESCRIPTION	PART NO.	Qty.
1	Shaft*	3589-(?)	1
2	Set Screw	1441-2	2
3	Retaining Ring**	3616	1
4	Bearing**	2715	1
5	Snap Ring**	3573	1
6	Backplate	3568	1
7	Spacer	3590	1
8	Spring**	2606	6
9	Clutch plate Assy**	3571	1
10	Retaining Ring**	3574	1
11	Bearing**	2717	1
12	Retaining Ring**	2716	1
13	Cylinder	4177	1
14	O Ring**	2720	1
15	O Ring**	4176	1
16	Piston	4178	1
17	Retaining Ring**	2714	1
18	Bearing**	3583	1
19	Snap Ring**	3587	1
20	Key	2621-1	1
*Bore size must be specified when ordering or for replacement			
Repair Kit (Includes Items with**)		4179K	

**THE CARLSON COMPANY, INC.**

PHONE: (316) 744-0481

FAX: (316) 744-2144

6045 NORTH BROADWAY

E-MAIL: sales@carlsoncompany.com

WICHITA, KANSAS 67219

WEB: www.carlsoncompany.com

USA