

MODEL ECB875-XL

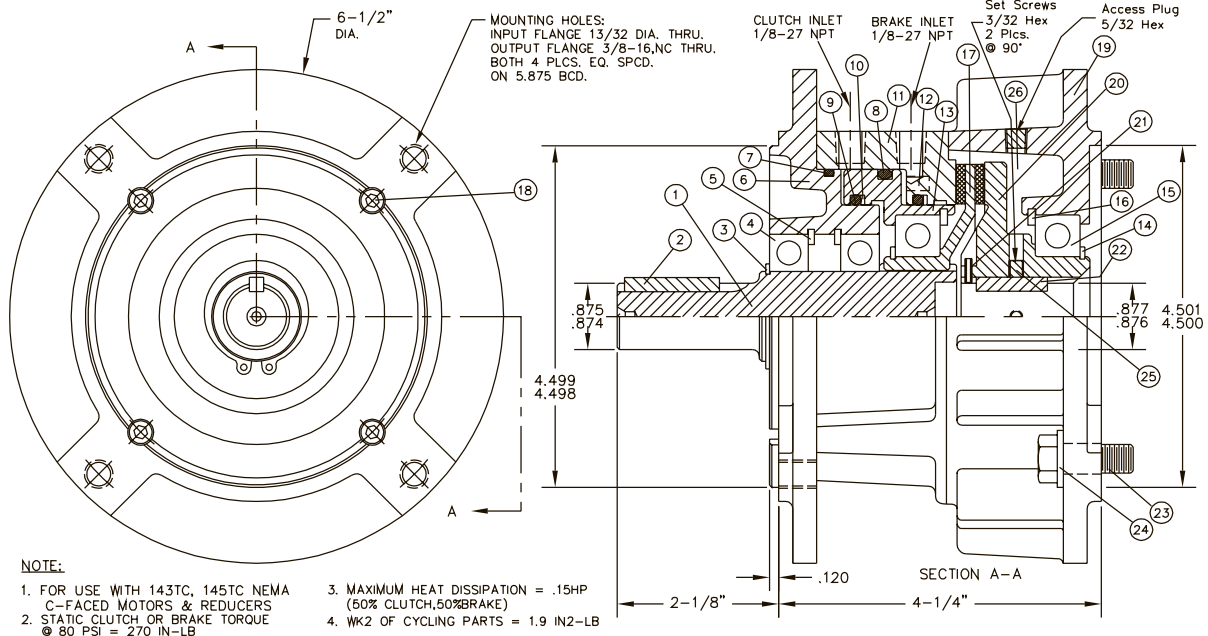

General Description

The model ECB875-XL is a totally enclosed pneumatic clutch/brake. Use 20-80psi air pressure applied selectively to each port to engage the clutch or the brake. The single piston design prevents any overlap between clutch and brake. This model is made with a female c-face on the input side and a male c-face on the output side. The unit is assembled and ready for use as shipped.

Installation

Before installing the unit in the female c-face mounting, be sure the hollow shaft is clean and free of burrs. Install the 3/16x1-1/4Lg key in the unit's output shaft. Dress the key or shaft until an easy sliding fit is obtained. Coat the unit's output shaft with anti-seize to prevent corrosion. Slide the unit into the mounting and bolt 4 places with the appropriate length capscrews. Final tighten these bolts. Install the 3/16x7/8Lg key provided in the motor shaft. Slide the key all the way toward the motor so the key is at least 1/2" back from the end of the motor shaft. Apply anti-seize to the motor shaft to prevent corrosion. Install the motor into the unit's input bore and slide it in until the flanges meet. Install and tighten the 4 capscrews and lockwashers. Final tighten these bolts. Remove the access plug and insert a 3/32" allen wrench to tighten the hub set-screws to the motor shaft. Rotate the motor shaft while feeling with the allen wrench until it drops into the tapped hole. There are (2) set-screws 90° apart. Reinstall the access plug. Install the air lines to the 1/8"NPT ports. Use a dryer and a lubricator in the air line to prevent internal rust and promote long life. Check the unit several times after put into use to be sure it is not running hot. The maximum case temperature should be 180°F.

Maintenance

This model clutch/brake has no items requiring maintenance or adjustment. Items which have limited life and may eventually need replacing include: rotor, orings, and bearings. These items are available in a repair kit as shown on the parts list.

Removal

Remove the access plug from the housing and insert a 3/32" allen wrench. Rotate the motor shaft while feeling the allen wrench until it drops into the setscrew hole. There are (2) setscrews, one over the key and one at 90°. Loosen both about 2 turns. Remove the (4) capscrews fastening the motor to the input flange and slide the motor out. Remove the air lines. Remove the (4) capscrews fastening the clutch/brake to the driven c-face. Slide the clutch/brake out of the c-face.

ITEM	DESCRIPTION	PART NO.	QTY.
1.	Shaft	5511	1
2.	Key	2621-1	1
3.	Snap Ring*	3587	1
4.	Bearing*	2747	2
5.	Snap Ring *	3842	2
6.	Output Flange	5512	1
7.	O Ring*	3955	1
8.	O Ring*	3890	1
9.	O Ring*	3846	2
10.	Scraper Ring*	5520	2
11.	Housing	5513	1
12.	Spring*	5402	8
13.	Piston	5514	1
14.	Snap Ring*	3760	2
15.	Bearing*	3950	2
16.	Snap Ring*	3759	2
17.	Rotor*	5516	1
18.	Capscrew	1656-11	4
19.	Input Flange	5517	1
20.	Input Plate	5518	1
21.	Roll Pin	5462	1
22.	Key*	5437	1
23.	Capscrew	1357-3	4
24.	Lock Washer	1019-6	4
25.	Set Screw	5433-2	2
26.	Plug	2596	1
	Repair Kit (includes items with*)	5509K	

THE CARLSON COMPANY, INC.

PHONE: (316) 744-0481

FAX: (316) 744-2144

6045 NORTH BROADWAY

E-MAIL: sales@carlsoncompany.com

WICHITA, KANSAS 67219

WEB: www.carlsoncompany.com

USA